

ITEM	NPS-DN		Class 800 Dimensions			
	in	mm	d	L	-	NPT
-	1/2	15	10	79	-	1/2
-	3/4	20	13	92	-	3/4
-	1	25	17	111	-	1
-	1-1/4	32	23	120	-	1-1/4
-	1-1/2	40	28	120	-	1-1/2
-	2	50	36	140	-	2

10	Bonnet Bolt	ASTM A193 Gr.B7	
9	Bonnet	ASTM A105N	
8	Gasket	FLEXIBLE GRAPHITE+304	
7	Swing Arm	ASTM A105N	
6	Hinge Pin	ASTM A276 410	
5	Hinge	ASTM A105N	
4	Nut	ASTM A194 Gr.2H	
3	Disc	ASTM A182 F6a CL.2	
2	Seat	ASTM A182 F6a CL.2	
1	Body	ASTM A105N	
NO	PART NAME	MATERIAL	REMARKS

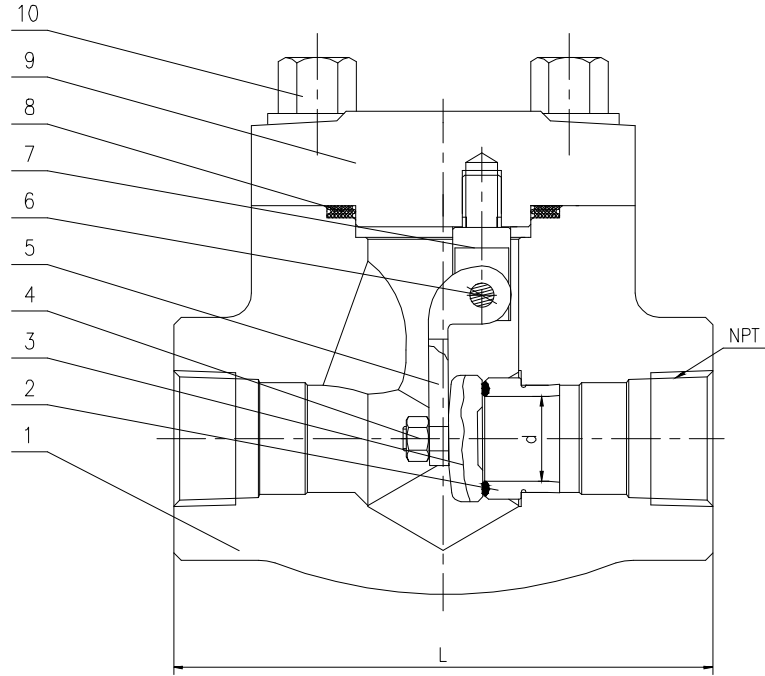

**FORMEN VALVE**  
 INFO@FORMENVALVE.COM WWW.FORMENVALVE.COM  
 FORGED STEEL SWING CHECK NPT VALVE  
 CLASS 800LB

REVISION RECORD						INSPECTION & TEST: API 598				MATERIAL: A105N				
REV. No.	DESCRIPTION	DATE	Des'd	Rev'd	APP'D	END	ASME B1.20.1	SHELL	HYDRO	21.0	CLASS:	800LB	DRAWING BY:	HZH
						FACE TO FACE	MANUF.STD	SEAT	AIR	0.6	SIZE:	SEE TABLE	CHK'D & APP'D BY:	WLS
						DESIGNED	API 602	BACK SEAT	HYDRO	15.4	TEMPERATURE:	-29~425°C	DATE:	2017/03/27
											MEDIA:	W.O.G		